

# DATA SHEET

## Three Phase Induction Motor - Squirrel Cage



Customer : GOL PUMP TECHNOLOGY, INC.

Product line : IE3 Premium Efficiency Alumínio Multi Montagem  
Tru Metric

Frame	: 90S/L	Locked rotor time	: 14 s (hot) 25 s (cold)
Output	: 2 HP (1.5 kW)	Temperature rise	: 80 K
Poles	: 4	Duty cycle	: S1
Frequency	: 60 Hz	Ambient temperature	: -20 °C to +40 °C
Rated voltage	: 230/460 V	Altitude	: 3280 ft
Rated current	: 5.66/2.83 A	Protection degree	: IP55
L. R. Amperes	: 47.0/23.5 A	Cooling method	: IC411 - TEFC
LRC	: 8.3 Code L	Mounting	: B35T
No load current	: 3.10/1.55 A	Rotation <sup>1</sup>	: Both
Rated speed	: 1755 rpm	Noise level <sup>2</sup>	: 49.0 dB(A)
Slip	: 2.50 %	Vibration class	: A
Rated torque	: 8.11 Nm	Starting method	: Direct On Line
Locked rotor torque	: 300 %	Coupling	: Direct
Pull up torque	: 255 %	Approx. weight <sup>3</sup>	: 43.0 lb
Breakdown torque	: 350 %	Painting plan	: 207N
Insulation class	: F	Color	: RAL 5009
Service factor	: 1.25	Design	: N
Moment of inertia (J)	: 0.1566 sq.ft.lb		

Output	50%	75%	100%	Load type	: -
Efficiency (%)	82.5	85.5	86.5	Load torque	: -
Power Factor	0.55	0.68	0.77	Load inertia (J=GD <sup>2</sup> /4)	: -

Bearing type	Drive end	Non drive end	Foundation loads
	6205-ZZ	6204-ZZ	Max. traction : 704.8 N
Lubrication interval	-	-	Max. compression : 896.1 N
Lubricant amount	-	-	
Lubricant type	MOBIL POLYREX EM		

Notes  
See notes on page 2.

This revision replaces and cancel the previous one, which must be eliminated.  
(1) Looking the motor from the shaft end.  
(2) Measured at 1m and with tolerance of +3dB(A).  
(3) Approximate weight, subject to be changed after manufacturing process.  
(4) At 100% of full load.

These are average values based on tests with sinusoidal power supply, subject to the tolerances stipulated in IEC 60034-1.

Rev.	Changes Summary		Rev.	Checked	Date
Performed by	johnson		1228356928		
Checked by	AUTOMATICO		Page	Rev.	
Date	30/10/2021		1 / 5	0	

# DATA SHEET

## Three Phase Induction Motor - Squirrel Cage



Customer : GOL PUMP TECHNOLOGY, INC.

Product line : IE3 Premium Efficiency Alumínio Multi Montagem  
Tru Metric

### Thermal protection

ID	Application	Type	Quantity	Sensing Temperature
1	Winding	Thermistor - 2 wires	1 x Phase	155°C

### Notes

Standards	Specification	: MG1 - Part 10	Vibration	: MG1 - Part 7
	Test	: MG1 - Part 12	Tolerance	: MG1 - Part 12
	Noise	: MG1 - Part 9		

This revision replaces and cancel the previous one, which must be eliminated. (1) Looking the motor from the shaft end. (2) Measured at 1m and with tolerance of +3dB(A). (3) Approximate weight, subject to be changed after manufacturing process. (4) At 100% of full load.	These are average values based on tests with sinusoidal power supply, subject to the tolerances stipulated in IEC 60034-1.
--------------------------------------------------------------------------------------------------------------------------------------------------------------------------------------------------------------------------------------------------------------------------------------------	----------------------------------------------------------------------------------------------------------------------------

Rev.	Changes Summary	Rev.	Checked	Date
Performed by	johnson			1228356928
Checked by	AUTOMATICO		Page	Rev.
Date	30/10/2021		2 / 5	0

# TORQUE AND CURRENT VS SPEED CURVE

## Three Phase Induction Motor - Squirrel Cage



Customer : GOL PUMP TECHNOLOGY, INC.

Product line : IE3 Premium Efficiency Alumínio Multi Montagem  
Tru Metric

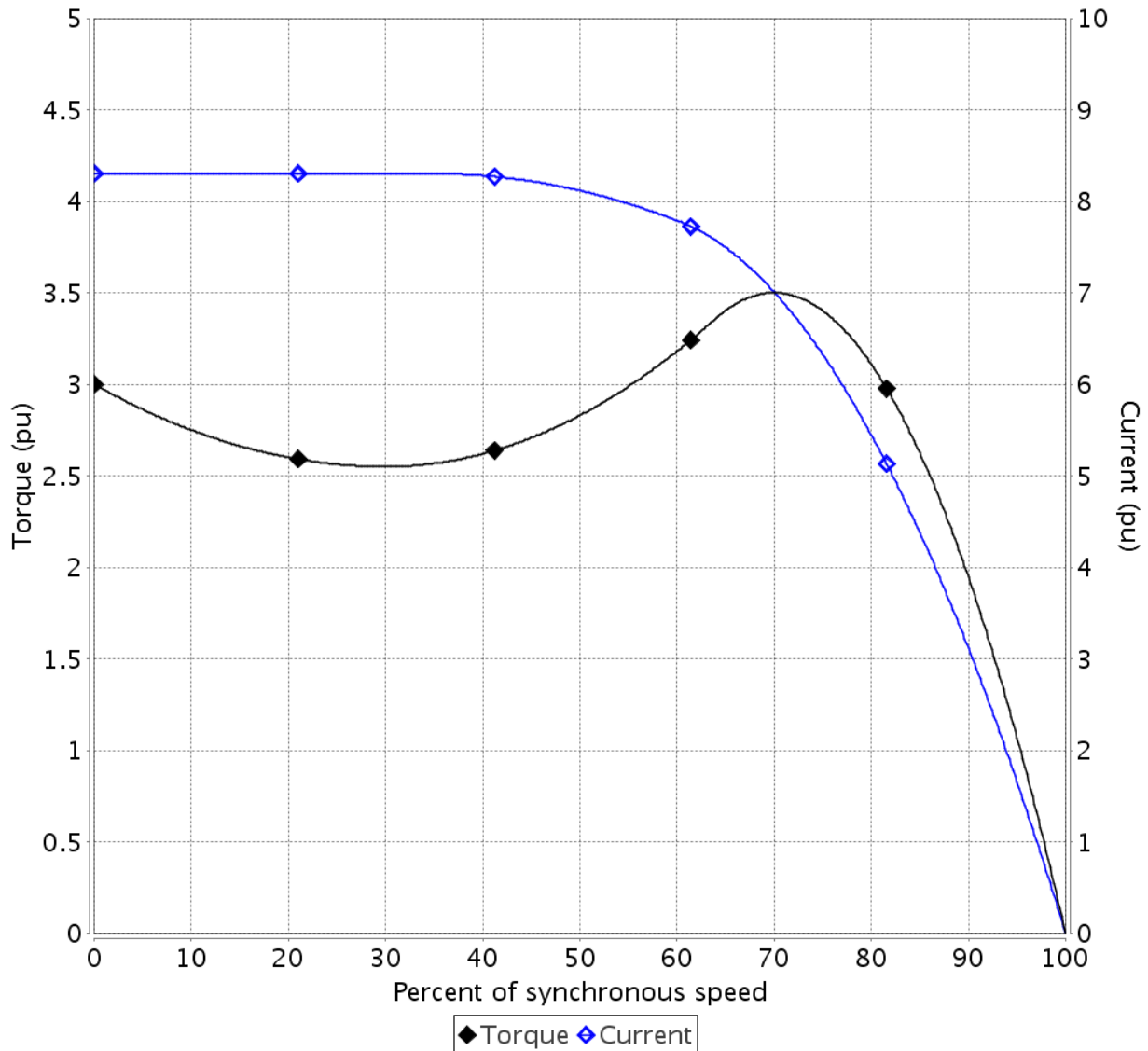

Performance : 2 HP (1.5 kW) 230/460 V 60 Hz 4P 90S/L

Rated current	: 5.66/2.83 A	Moment of inertia (J)	: 0.1566 sq.ft.lb
LRC	: 8.3 Code L	Duty cycle	: S1
Rated torque	: 8.11 Nm	Insulation class	: F
Locked rotor torque	: 300 %	Service factor	: 1.25
Breakdown torque	: 350 %	Temperature rise	: 80 K
Rated speed	: 1755 rpm	Design	: N

Locked rotor time 100% : 14 s (hot) 25 s (cold)

Load inertia (J=GD<sup>2</sup>/4) : 0.1566 sq.ft.lb

Rev.	Changes Summary	Rev.	Checked	Date
Performed by	johnson	1228356928		
Checked by	AUTOMATICICO			
Date	30/10/2021			
		Page	Rev.	
		3 / 5	0	

# LOAD PERFORMANCE CURVE

## Three Phase Induction Motor - Squirrel Cage



Customer : GOL PUMP TECHNOLOGY, INC.

Product line : IE3 Premium Efficiency Alumínio Multi Montagem  
Tru Metric

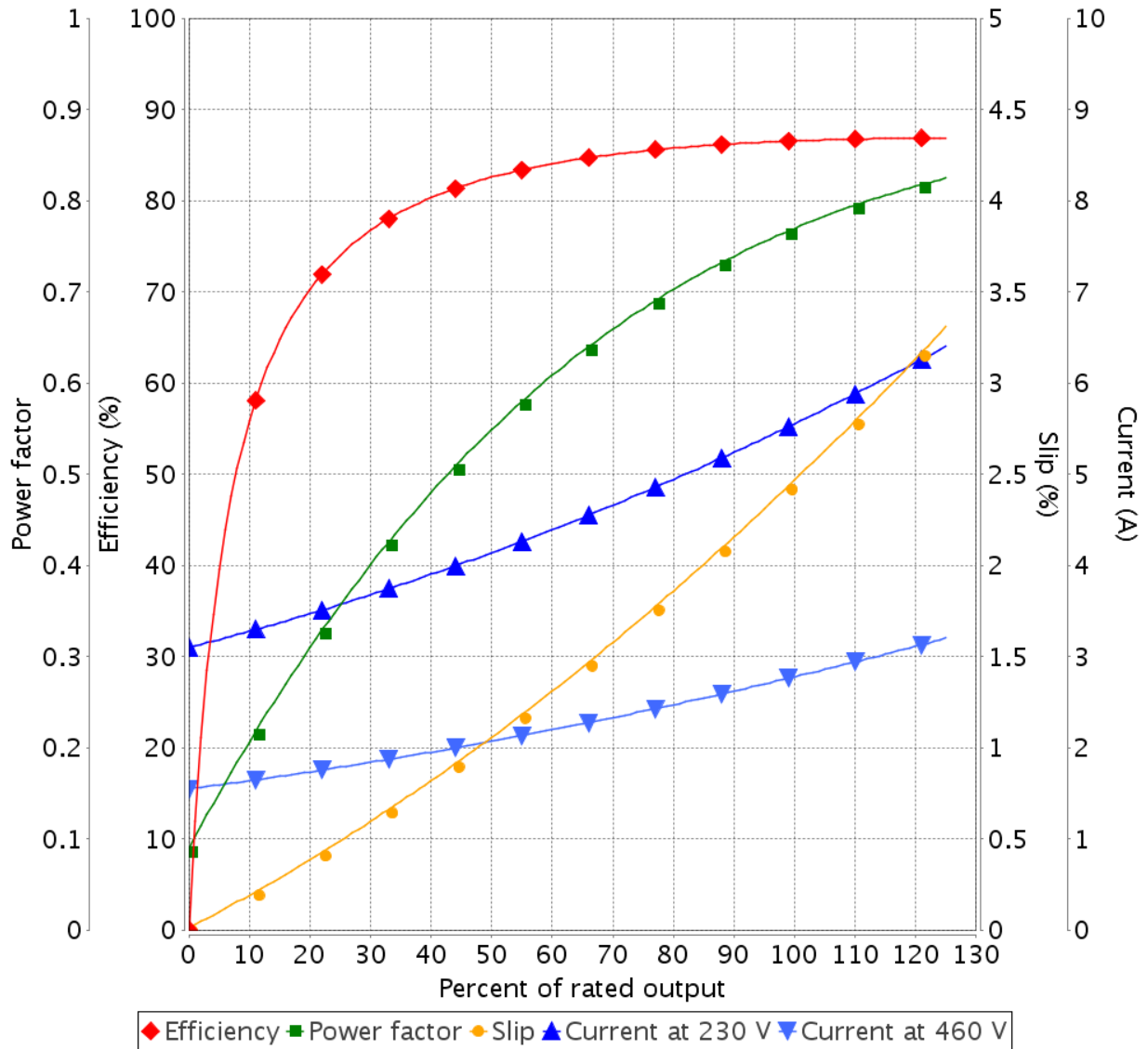

Performance : 2 HP (1.5 kW) 230/460 V 60 Hz 4P 90S/L

Rated current : 5.66/2.83 A	Moment of inertia (J) : 0.1566 sq.ft.lb
LRC : 8.3 Code L	Duty cycle : S1
Rated torque : 8.11 Nm	Insulation class : F
Locked rotor torque : 300 %	Service factor : 1.25
Breakdown torque : 350 %	Temperature rise : 80 K
Rated speed : 1755 rpm	Design : N

Rev.	Changes Summary	Rev.	Checked	Date
Performed by	johnson		Page	Rev.
Checked by			4 / 5	0
Date	30/10/2021			

# THERMAL LIMIT CURVE

## Three Phase Induction Motor - Squirrel Cage



Customer : GOL PUMP TECHNOLOGY, INC.

Product line : IE3 Premium Efficiency Alumínio Multi Montagem  
Tru Metric

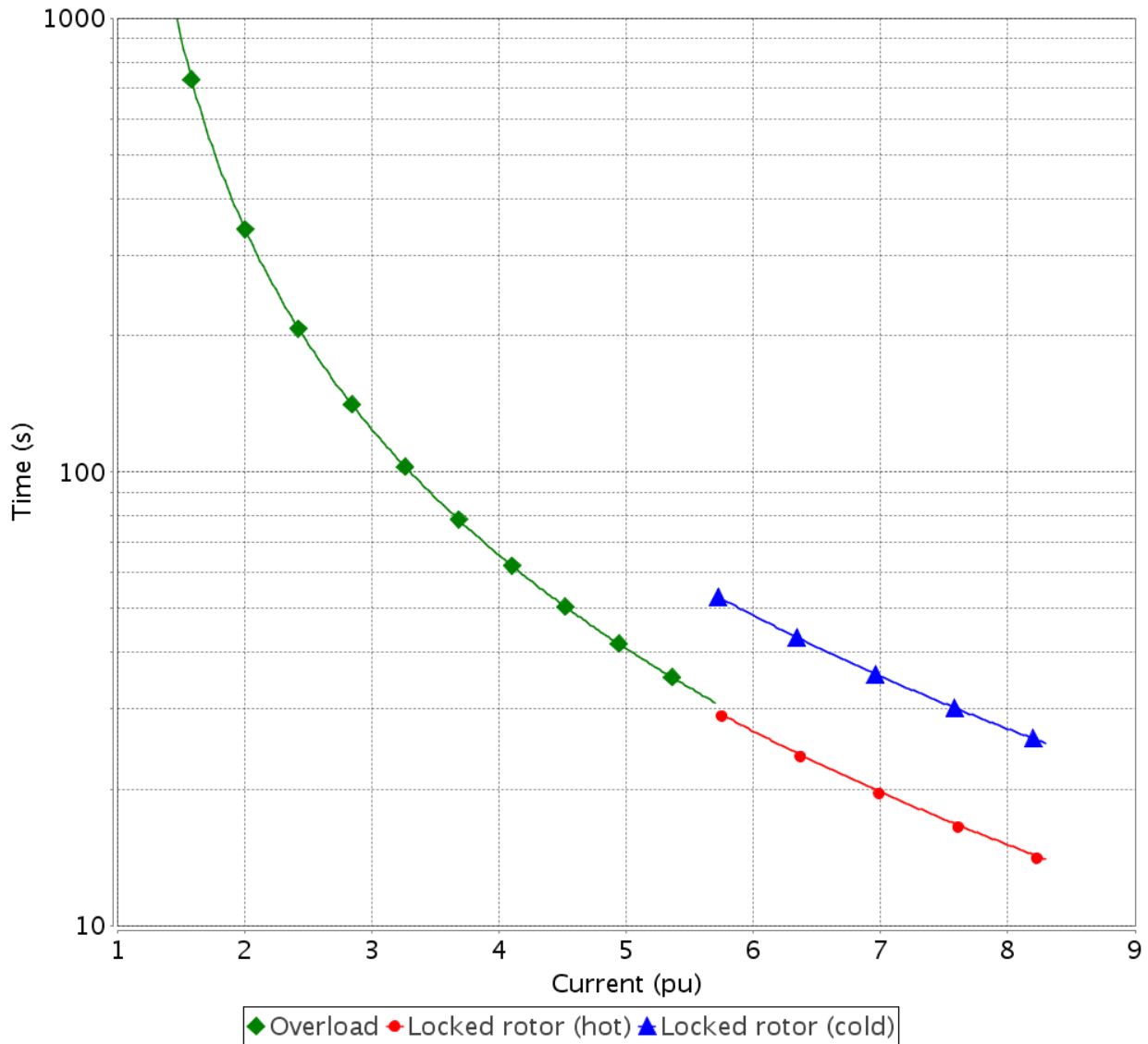

Performance : 2 HP (1.5 kW) 230/460 V 60 Hz 4P 90S/L

Rated current	: 5.66/2.83 A	Moment of inertia (J)	: 0.1566 sq.ft.lb
LRC	: 8.3 Code L	Duty cycle	: S1
Rated torque	: 8.11 Nm	Insulation class	: F
Locked rotor torque	: 300 %	Service factor	: 1.25
Breakdown torque	: 350 %	Temperature rise	: 80 K
Rated speed	: 1755 rpm	Design	: N

Heating constant : 16.6 min

Cooling constant : 49.8 min

Rev.	Changes Summary		Rev.	Checked	Date
Performed by	johnson				
Checked by				Page	Rev.
Date	30/10/2021			5 / 5	0

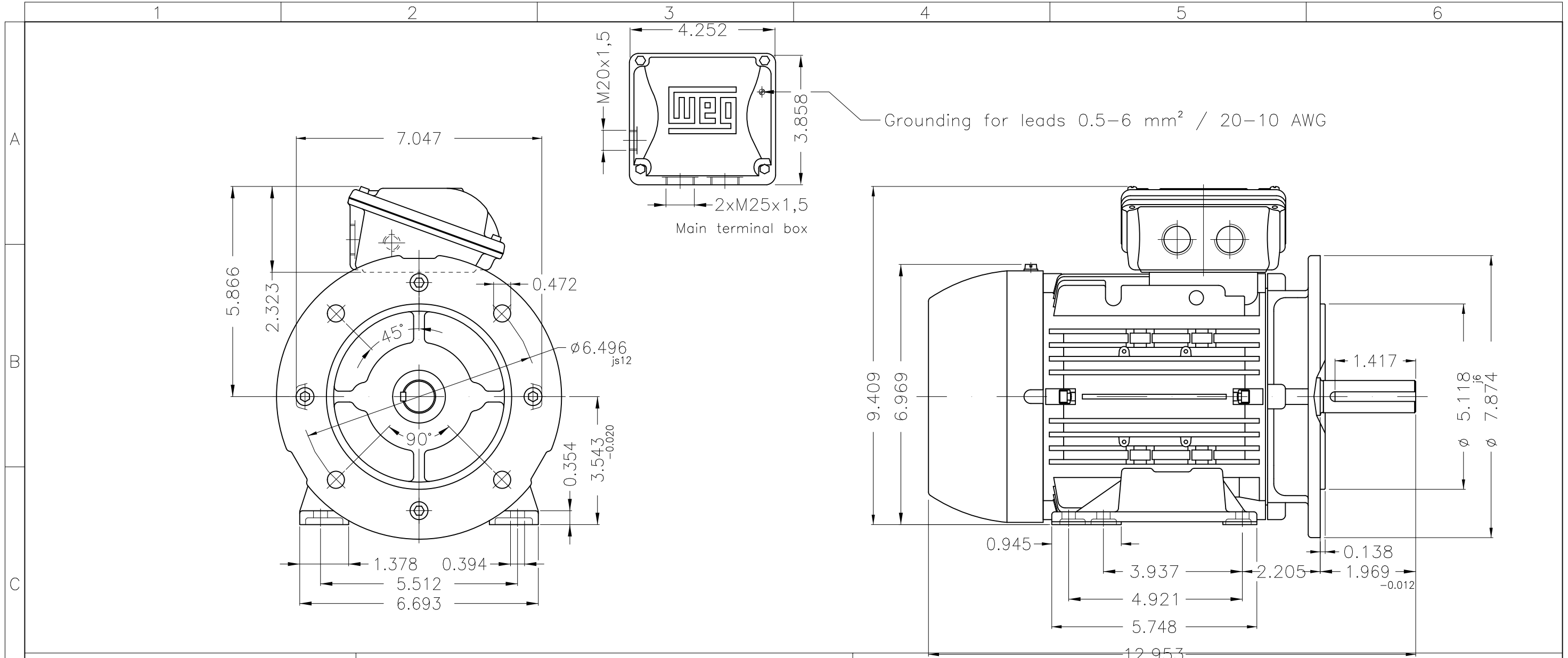

Thermal protection to switch off - thermistors 155°C  
 Color RAL 5009  
 Painting plan 207N  
 Mounting B35T

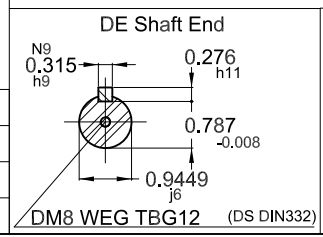

2 HP 04 Poles 60 Hz A

**GOL PUMP TECHNOLOGY, INC.**

ECM	LOC	SUMMARY OF MODIFICATIONS	EXECUTED	CHECKED	RELEASED	DATE	VER
EXECUTED	PIRWBUSER	THREE PHASE MOTOR TRU-METRIC P. EFF AL					
CHECKED		FRAME 90S/L IP55 TEFC					
RELEASED							
REL DT.		WMO Jaragua do Sul	Product Engineering	SHEET	1 / 1		

**PREVIEW**

**WDD**

Dimensions in inches XME A3