

DATA SHEET

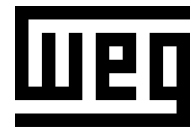

Three Phase Induction Motor - Squirrel Cage

Customer : _____

Product line : NEMA Premium Efficiency Three-Phase
 Product code : 5160747
 Catalog # : 02518ET3E284TF3-W22

Frame	: 284T	Locked rotor time	: 43s (cold) 24s (hot)
Output	: 25 HP (18.5 kW)	Temperature rise	: 80 K
Poles	: 4	Duty cycle	: Cont.(S1)
Frequency	: 60 Hz	Ambient temperature	: -20°C to +40°C
Rated voltage	: 230/460 V	Altitude	: 1000 m.a.s.l.
Rated current	: 59.0/29.5 A	Protection degree	: IP55
L. R. Amperes	: 366/183 A	Cooling method	: IC411 - TEFC
LRC	: 6.2x(Code G)	Mounting	: F-3
No load current	: 21.0/10.5 A	Rotation ¹	: Both (CW and CCW)
Rated speed	: 1765 rpm	Noise level ²	: 63.0 dB(A)
Slip	: 1.94 %	Starting method	: Direct On Line
Rated torque	: 74.2 ft.lb	Approx. weight ³	: 416 lb
Locked rotor torque	: 240 %		
Breakdown torque	: 270 %		
Insulation class	: F		
Service factor	: 1.25		
Moment of inertia (J)	: 5.11 sq.ft.lb		
Design	: B		

Output	25%	50%	75%	100%	Foundation loads	
Efficiency (%)	91.7	92.4	93.0	93.6	Max. traction	: 811 lb
Power Factor	0.46	0.70	0.80	0.84	Max. compression	: 1228 lb

	Drive end	Non drive end
Bearing type	: 6311 C3	: 6211 C3
Sealing	: V'Ring	: V'Ring
Lubrication interval	: 20000 h	: 20000 h
Lubricant amount	: 18 g	: 11 g
Lubricant type	: Mobil Polyrex EM	

Notes
 USABLE @208V 65.2A SF 1.15 SFA 75.0A

This revision replaces and cancel the previous one, which must be eliminated.
 (1) Looking the motor from the shaft end.
 (2) Measured at 1m and with tolerance of +3dB(A).
 (3) Approximate weight subject to changes after manufacturing process.
 (4) At 100% of full load.

These are average values based on tests with sinusoidal power supply, subject to the tolerances stipulated in NEMA MG-1.

Rev.	Changes Summary	Performed	Checked	Date
Performed by			Page	Revision
Checked by			1 / 1	
Date	23/06/2022			

1 2 3 4 5 6

A

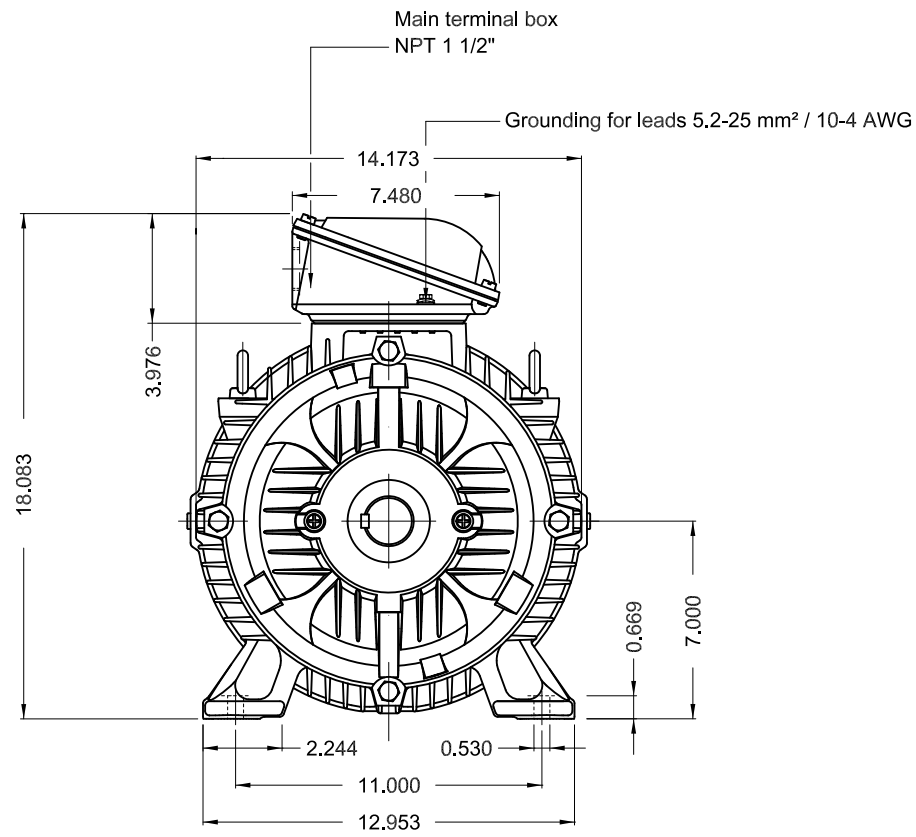

B

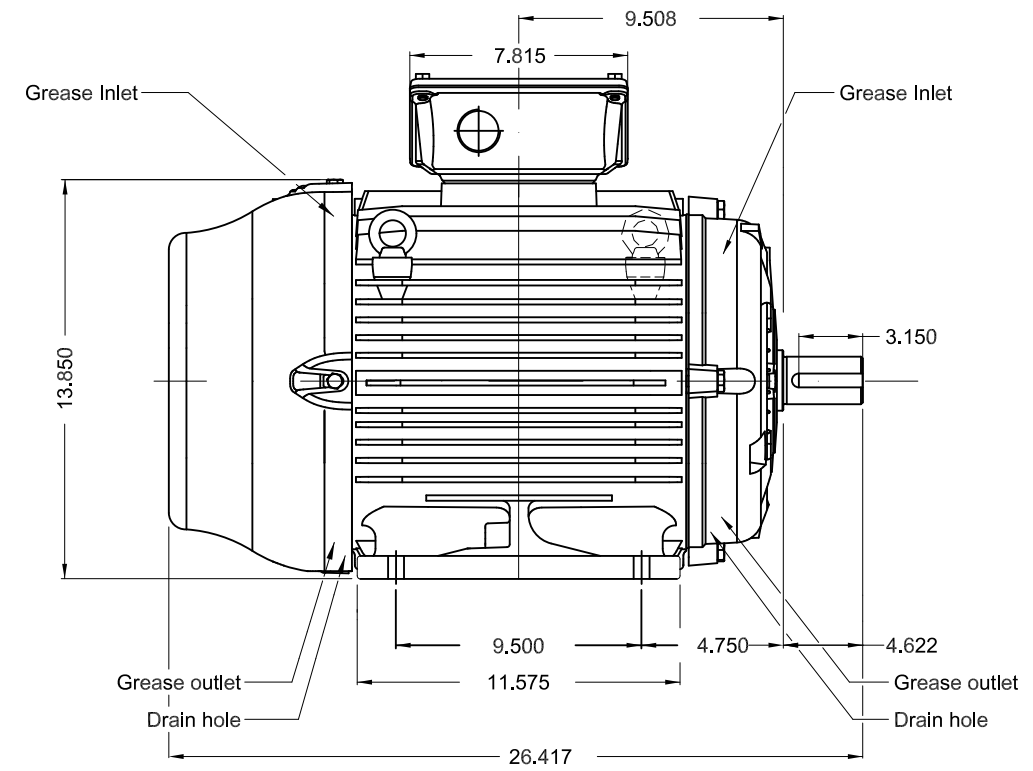

C

D

E

Color RAL 5009
 Painting plan 203A
 Mounting B3T

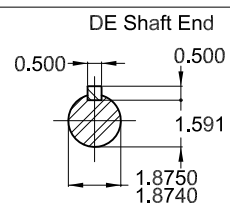

25 HP 04 Poles 60 Hz A

ECM	LOC	SUMMARY OF MODIFICATIONS	EXECUTED	CHECKED	RELEASED	DATE	VER
EXECUTED	HYBRISUSER	THREE PH. MOTOR W22 PREM. EFF. FRAME 284T IP55 TEFC					
CHECKED							
RELEASED							
REL DT.	WMO		Jaragua do Sul	Product Engineering			

PREVIEW
 WDD



SHEET 1 / 1

Dimensions in inches

XME A3



FOR SAFE AREA
Mod.TE1BFOXON
CC029A



For use on 60Hz
Class I, Div 2, Gr A, B, C and D - T3
Class I, Zone 2, IIC - T3
Class II, Div 2, Gr F and G - T4
For use on PWM: Gr. A, B, C, D and F,
VT 1000:1, CT 20:1, 1.00SF - T3A

MODEL 02518ET3E284TF3-W22

Inverter Duty Motor
Severe Duty

PH3 60Hz Fr. 284T 1000m.a.s.l. IP55 TEFC 386lb

V 230/460 A 59.0/29.5

HP 25 kW 18.5

SF 1.25 SFA 73.8/36.9

RPM 1770 PF 0.84

AMB 40°C INS cl. F DT80K NEMA NOM EFF 93.6%

DUTY CONT. DES B Code G

USABLE @208V 65.2A SF 1.15 SFA 75.0

25HP 18.5kW 50Hz 380V 35.9A 1455RPM SF 1.00 EFF 91.0% (IE1)

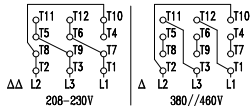

 → 6311-C3 (18g)
→ 6211-C3 (11g)

 MOBIL POLYREX EM (20000h)

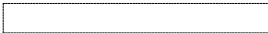

MADE IN BRAZIL
11807254